

# SSI Technologies - Application Note AT-AN3

## Acu-Trac® NEMA 6 Liquid Level Transmitter

### Product Overview

#### Product Description

The Acu-Trac® NEMA6 liquid level transmitter is a non-contact transmitter that is a direct replacement for level senders on tanks with depths up to  $\leq 3.0$  meters (118 inches).

The NEMA6 liquid level transmitter offers a choice of outputs (analog current loop; ratiometric voltage; or non-ratiometric voltage).

The NEMA6's RS-485 bus allows real time processing of fuel data and messaging over the RS-485 bus

The RS-485 bus also provides the user flexibility to program the NEMA6 liquid level transmitter for tank configuration, digital filtering, transmitter mounting offset, gauge drive output full and empty endpoints and communication mode.



#### Product Features

- **KYNAR® Package:** Chemically resistant Polyvinylidene Fluoride (PVDF) package.
- **More Accurate:** 2% of tank volume
- **More Reliable:** Acu-Trac® NEMA6 liquid level transmitter is non-contacting. Resistive float sender have a wiper that slides across a resistive strip that with time can wear and cause intermittent or complete loss of the signal.
- **Non-Invasive:** Acu-Trac® NEMA6 liquid level transmitter mounts to the same opening as the resistive float sender, but does not protrude into the tank.
- **Digital Filtering:** User programmable time constant in digital filtering eliminates errors due to fluids sloshing in mobile tanks.
- **Tank Profiling:** User programmable strapping tables for unique tank shapes.
- **Chemical compatibility:** Acu-Trac® NEMA6 liquid level transmitter works with a wide variety of media including diesel, motor oil, hydraulic fluid and black water.
- **Self Test/Diagnostics:** Power Up Test verifies liquid level transmitter is operating properly and diagnostic messages are sent over the RS-485 bus.
- **Real Time Fuel Data:** Real time fuel data over the J1708 data link for on vehicle communication.
- **RS-485 Messaging:** Three types of messages are provided on the RS-485 bus – setup and programming commands, timed data broadcast message, and diagnostic messages.
- **NEMA 6 Rating**
- **CE Mark Class B Rating**



# SSI Technologies - Application Note AT-AN3

## Acu-Trac® NEMA 6 Liquid Level Transmitter

### Product Overview

#### Measurement Technology

The traditional resistive float sender uses a potentiometer attached to a float at the end of an actuating arm to provide a level indication. This technology interfaces with the instrument cluster's fuel gauge which is typically a coil driven needle gauge. As the resistive float sender's resistance changes with level, the current through the coil in the gauge changes causing a deflection of the needle. This approach has been used for many years.

Acu-Trac® NEMA6 uses ultrasonic technology to generate a high frequency sound wave and measure the time for the echo to reflect off of the liquid's surface and return. The distance from the liquid level transmitter to the fuel is calculated based on the speed of sound. The measured distance is converted into a voltage that drives the fuel gauge based on a strapping table contained in the liquid level transmitter.

The measured distance is converted into a percentage of tank capacity (Full to Empty), and volumes in gallons based on the geometry of the tank.

#### Electrical Interface

The Acu-Trac® NEMA6 liquid level transmitter is available with a choice of either a 12V or 24V operating voltage.

The output can be either a current loop analog output (4-20mA) or a ratiometric voltage output (0.5 Vdc to 9.5 Vdc) or a non-ratiometric voltage output.

A 9600 Baud RS-485 serial data interface is provided for transmission of fuel data to other modules on the bus.

#### Electrical Connection Options

Electrical Connection Options Include:

- Integral Packard Electric connector which mates with Packard part number 12148045 and Packard Terminal 12048074.
- 2.5 meter cable with pig tail connections.

Electrical Connections:

- Electrical Ground
- Supply Power
- (B) RS485 Serial Data
- Analog Output
- (A) RS485 Serial Data

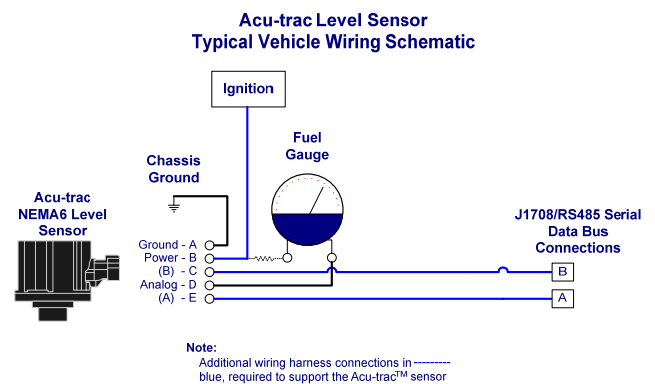

Figure 1, Typical Acu-Trac® NEMA 6 Wiring

# SSI Technologies - Application Note AT-AN3

## Acu-Trac® NEMA 6 Liquid Level Transmitter

### Product Overview

#### Mounting

Mechanical package options include:

- Standard SAE 1810 5 Hole bolt pattern Standard Mounting (shown in the Figure 3)
- NPT mount  
1" Thread

When mounting, it is important to place the NEMA6 liquid level transmitter in the center of the tank parallel to the liquid level and with no obstructions in the beam path to the liquid.

#### Cone Angle

Acu-Trac® NEMA6 liquid level transmitter mounting that is not perpendicular to the liquid causes a reduction in liquid level transmitter performance. As shown in Figure 2, the amount of returned sound energy is dependent on mounting cone angle.

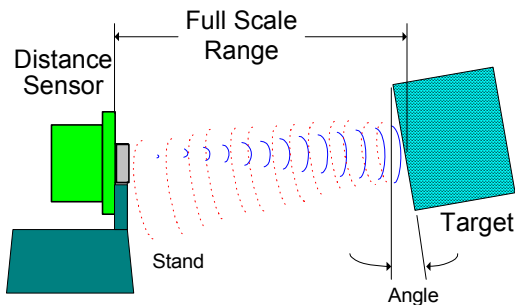

**Figure 2. Mounting Considerations.**

The Acu-Trac® NEMA6 liquid level transmitter maximum operating range (tank depth) decreases with angle. The maximum cone angle is 6°.

If the Acu-Trac® NEMA6 liquid level transmitter is pointed into free space (outside of operating cone angle), no echo will be received. Under this no echo condition, the Acu-Trac® NEMA6 liquid level transmitter will hold its output voltage constant. If the

no echo condition persists for 8 minutes, the Acu-Trac® level transmitter will set both the voltage output and the digital word to empty.

#### User Programmable Parameters

The Acu-Trac® NEMA6 liquid level transmitter can be uniquely configured using a standard Windows™ based PC and the Acu-Trac® configuration software kit. The kit includes a RS-485 to J1708 converter, Acu-Trac® Configuration Tools Software and instructions. The configuration tools software allows each system to be customized to accommodate any tank size or shape. The Acu-Trac® NEMA6 liquid level transmitter has the following user programmable features:

- 1) Digital Filtering Time Constant
- 2) Tank Configuration
- 3) transmitter Mounting Offset
- 4) Gauge Full and Empty Endpoints
- 5) Communication Mode

#### Digital Filtering Time Constant

Motion of the liquid media, can impact the performance of a liquid level transmitter. Wave motion creates noise in the measured data because the liquid level transmitter measures one distance at the wave peak and another distance during the wave troughs.

In certain highway and marine applications, this difference can be as high as 30% of full scale especially when traveling on curvy roads or in choppy waters.

Acu-Trac® NEMA6 liquid level transmitter has a user programmable digital filter to reduce error caused by sloshing liquids. The digital filter is user programmable for a time constant between 0 and 40 seconds.

# SSI Technologies - Application Note AT-AN3

## Acu-Trac® NEMA 6 Liquid Level Transmitter

### Product Overview

#### Tank Configuration

The tank's capacity, depth, shape and orientation can be programmed into the liquid level transmitter enabling volumetric fuel quantity or depth. The following volume and level proportioning operational modes are available:

- 1) Linear Level (% of capacity – distance)
- 2) Cylindrical Level (% of capacity – area)
- 3) Rectilinear (% of capacity – area)

#### Transmitter Mounting Offset

The Transmitter Mounting Offset is the distance in inches from the mounting face of the level sensor to the top of the tank. Calculation of percent of capacity excludes this distance. Transmitter mounting offset is used to accommodate unusual tank implementation.

#### Gauge Full and Empty Endpoints

The gauge drive outputs full and empty endpoints can be independently programmed. The user has the option of programming either a linear output mode or a table output mode.

In the linear output mode, the sensor automatically proportions the output to a linear straight line fit based on the measured fuel volume.

In the table output mode, the user sets up a look up table in the sensor. This mode of operation is typically used to set up a non-linear gauge without knowing the characteristics of the gauge. The user would simply hook up the gauge and use the Learn Gauge Dialog on the Acu-Trac® Level Sensor Configuration Software to dial in the settings for empty,  $\frac{1}{4}$ ,  $\frac{1}{2}$ ,  $\frac{3}{4}$ , and full.

Both modes support guard band settings. The empty guard band allows the user to set the percent of the fuel left in the tank when the level sensor is to indicate an empty reading. The full guard band allows the user to set the percent of fuel to drop below before the gauge leaves the full indication.

#### Real Time Data Transmission

The Acu-Trac® NEMA6 liquid level transmitter operates in a RS-485 Burst Communication Mode and has a MID of 143. The liquid level transmitter is constantly monitoring the liquid level within the tank and also the vehicle broadcasts over the RS-485 bus.

The standard TIA/EIA RS-485 serial data bus enables the NEMA6 liquid level transmitter to communicate and share data in real time with the other modules on the vehicle bus with Message Transmitter Identifications (MID)  $\geq 128$ .

The NEMA6 liquid level transmitter has three types of messages:

- 1) Setup and Programming Commands
- 2) Timed Broadcast Data Message
- 3) Diagnostic Message

The Setup and Programming Commands are used to program the NEMA6 liquid level transmitter for the tank's particular size, shape and installation.

The Timed Broadcast Data Message transmits measurement data from the NEMA6 liquid level transmitter to the other modules on the RS-485 bus twice a second.

The Diagnostic Message is reported instead of the Timed Broadcast Data Message whenever the NEMA6 liquid level transmitter has identified an active transmitter fault during its power up tests.

Refer to the Acu-Trac® Application Note AT-AN1 for a detailed description of the RS-485 burst communication mode and messages.



# SSI Technologies - Application Note AT-AN3

## Acu-Trac® NEMA 6 Liquid Level Transmitter

### Product Overview

#### Electrical Specifications

|                      |   |
|----------------------|---|
| Supply Voltage       | 12V (10-16 V) OR<br>24V (11-34V)  |
| Output Options       | Ratiometric Voltage (12V)<br>(0.5 to 9.5 Vdc) OR<br>Non-Ratiometric Voltage (24V) OR<br>Current (4-20 mA) |
| Range                | Up to 3 m (118 inches)  |
| Accuracy             | 2 % of volume   |
| Operating Temp Range | -40 to 85 ° C   |
| Storage Temp Range   | -50 to 105 ° C  |
| Output Sink Current  | 50 mA max   |

**\*Note:** Acu-Trac® liquid level transmitters are not intended for use with gasoline.

#### Tested Conditions

|                         |  |
|-------------------------|--|
| Input Supply Transients | Reverse Battery -2x Volts<br>Over Voltage 2x Volts   |
| Transients              | Load Dump 120 Volts<br>ESD 15 KV   |
| EMI                     | Conducted 25 V/m<br>Radiated 40 V/m<br>Emissions 50DBuV/m max  |
| Mechanical Shock        | 20 G Shock   |
| Drop Test               | 1 meter Drop Test  |
| Vibration               | 4 Grms 12 hrs each axis  |
| Humidity                |  |
| Thermal Cycle           | 400 hrs (-40 to 85°C)  |
| Salt Fog                | 96 hours   |
| Thermal Shock           | 6 cycles (-40 to 85°C)   |
| Chemical Compatibility  | Diesel Fuel, Motor Oil, urea (ADBLUE), Water, Potable Water, Ethanol, Hydraulic Fluid, Engine Coolant. |

**Note:** Acu-Trac® is CE (European Conformity) and NEMA6 (National Electrical Manufacturers Association Accreditation) Certified.

#### Other Specifications

|                      |                |
|----------------------|----------------|
| SAE 5 Bolt Torque    | 10-15 in/lbs   |
| 1" Threaded Torque   | 3 ft/lbs       |
| Cone Angle           | +/- 6 degrees  |
| Dead Band (Top only) | 6 inches (max) |



# SSI Technologies - Application Note AT-AN3

## Acu-Trac® NEMA 6 Liquid Level Transmitter

### Product Overview

| PIN # | NAME   | DESCRIPTION          |
|-------|--------|----------------------|
| A     | GRND   | GROUND               |
| B     | PWR    | SUPPLY VOLTAGE       |
| C     | B      | RS 485 SERIAL DATA   |
| D     | ANALOG | SENSOR ANALOG OUTPUT |
| E     | A      | RS 485 SERIAL DATA   |

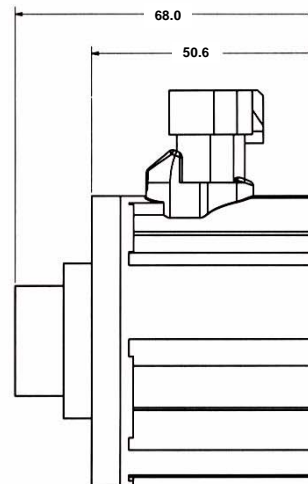
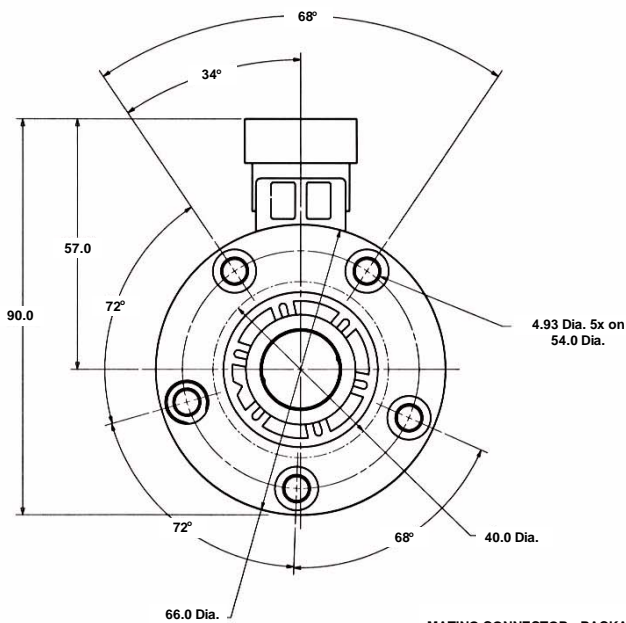
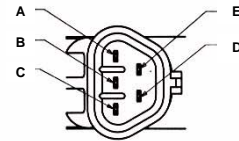

MATING CONNECTOR: PACKARD ELECTRIC CONNECTOR PART NO. 12148045 (NOT SHOWN)  
WITH PACKARD ELECTRIC TERMINAL PART NO. 12048074

Figure 2. Mounting

