

# SSI Technologies - Application Note AT-AN14

## Acu-Trac® Smart 485 Messaging

### General

SSI's Acu-Trac® Smart 485 ultrasonic level transducers broadcast and receive commands over a standard TIA/EIA RS-485 serial data bus enabling the transducers to communicate and share data with other modules located on the data link. The Smart 485 has two types of RS-485 messaging – programming commands and timed data broadcast message (PID 96).

The RS-485 data link is a serial data link meaning that messages are transmitted one bit at time in sequence until the entire message has been completed. Idle states, I.E. the down time in-between messages is used to signal the 485 bus availability to other transmitting nodes within the network.

The Acu-Trac® Smart 485 ultrasonic level transducer is designed to communicate at a rate of 9600 baud. During normal operation, the Acu-Trac® Smart 485 will broadcast a 19 byte volume measurement message every 0.50 seconds consuming approximately 4% of the available data link bandwidth.

For illustration purposes, all the message drawings depicted herein are referenced from the transmitting nodes perspective with the beginning of the message located on the drawing's right hand side and the message end located on the drawing's left.

### Message & Character Construction

Messages are formatted into a series of characters, 10

bits each, which are strung together to create a complete message as shown in the *RS-485 Message Construction* drawing below.

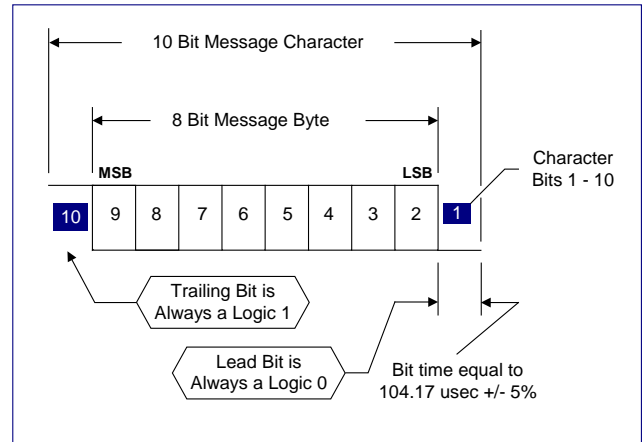

**Character Definitions**

Each character within the message string is comprised of a leading bit, or start bit, an 8 bit message byte followed by the trailing bit or stop bit. The start bit is always at a logic low level (0), while the trailing bit is always at a logic high level (1). The message byte is transmitted with the LSB, least significant bit, first followed in sequence with bits 2, 3, 4 and so on. See the above drawing titled *Character Definitions*.

The bit time for each character bit is 104.17  $\mu$ secs +/- 0.5% which effectively yields a baud rate of 9600 bits per second.

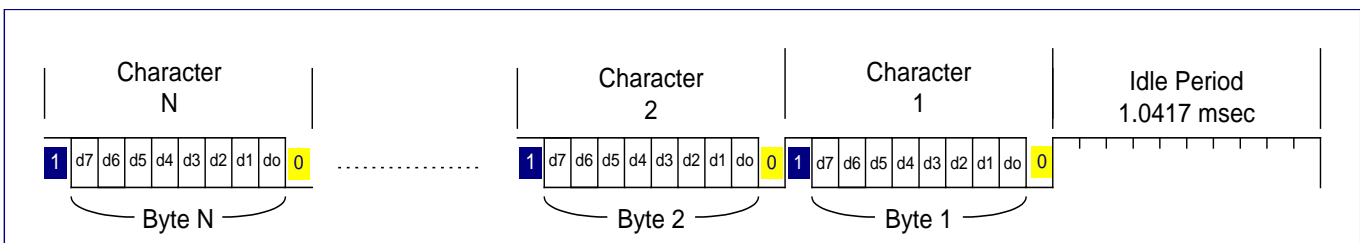

SSI TECHNOLOGIES, INC.  
 Controls Division  
 2643 W. Court Street  
 Janesville, WI 53548-5011  
 Phone: (608)758-1500  
 Fax: (608) 758-2491  
 www.ssitechnologies.com

### RS-485 Message Construction



SSI Technologies, Inc.

Copyright March 5, 2009  
 SSI Technologies Inc.  
 All Rights Reserved  
 Revision 1



RoHS

# SSI Technologies - Application Note AT-AN14

## Acu-Trac® Smart 485 Messaging

### Idle State

The 485 bus will return to a logic level high (1) when all of the data link transmitters are turned off as measured at the input to the 485 bus receiver(s); this is called the idle state.

As mentioned previously, the idle state in-between messages serves as a delimiter on the RS-485 bus. Any transmitting node on the 485 bus must first verify that this idle state has existed for at least 10 bit times or 1.0417 msecs before initiating a new message transmission.

A receiving node that has lost synchronization and cannot distinguish between the message stop bit and any other message high bit, can use the idle period to reestablish synchronization.

Re-synchronization is achieved by noting the receipt of 12 consecutive high logic bits. In the absence of errors, the first logic 0 following the receipt of 12 consecutive high bits is the start bit of the next message.

### SSI Message Format

All messages transmitted and received by the Acu-Trac® Smart 485 ultrasonic level transducer family follow the format depicted on the bottom of this page and described herein.

The first message byte, Message Transmitter Identification, is always the identification number of the device broadcasting the message. The Acu-Trac® Smart 485 ultrasonic level transducer uses 143 for its identification number.

The second message byte, Service Code, is always 254 for Acu-Trac® ultrasonic level transducer messages.

The third message byte, Message Receipt Identifier (177 for our example), provides the identification number for the intended message recipient.

The fourth message byte defines the Number of Remaining Characters in the message exclusive of the checksum. If the fourth byte is a one (1) then the message is a command and contains no data. If the fourth byte is greater than 1 then the sixth message byte will contain the number of data elements in the transmission.

The fifth message byte, Message Identifier, defines what the message is and/or is intended to accomplish. Acu-Trac® Smart 485's ultrasonic level transducer family responds to the following message identifiers:

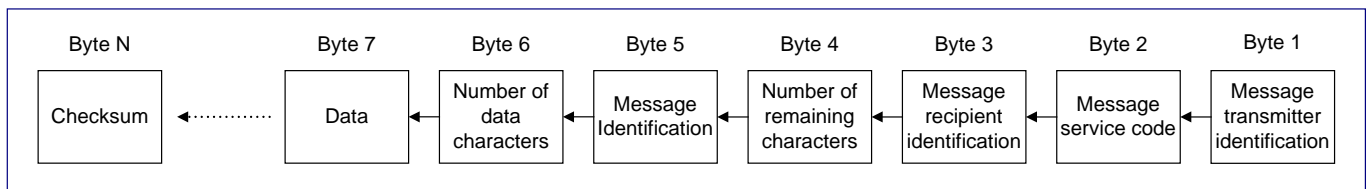

# SSI Technologies - Application Note AT-AN14

## Acu-Trac® Smart 485 Messaging

The Acu-Trac® Smart 485 ultrasonic level transducer will use the following message identifiers in its transmissions:

Identifier	Message
190	Measurement Broadcast

The sixth message byte, Number of Data Characters, denotes the number of data elements contained which are to follow and is only used in messages which contain data.

Bytes 7 through N-1, Data, are reserved for data characters.

The last message byte, Checksum, is the two's complement check sum for the entire message exclusive of the checksum and is used to qualify the validity of the message. A simple error detection scheme may be implemented by adding the checksum to the sum of all of the message characters, the 8 bit sum should be zero neglecting any carry(s) generated.

### Message Example

The following example describes the process for decoding the ultrasonic level transducer's volume message and how that message would look out on the RS-485 bus. A graphical depiction of the message is shown on the next page titled *Volume Measurement Message Example*.

In this example, the received message is as follows:

Byte1	Byte 2	Byte3	Byte4	Byte 5	Byte 6	Byte 7
<u>143</u>	<u>254</u>	<u>177</u>	<u>14</u>	<u>190</u>	<u>12</u>	<u>1</u>
Byte 8	Byte 9	Byte10	Byte11	Byte12	Byte13	Byte14
<u>64</u>	<u>1</u>	<u>224</u>	<u>48</u>	<u>48</u>	<u>48</u>	<u>51</u>
Byte15	Byte16	Byte17	Byte18	Byte19		
<u>51</u>	<u>50</u>	<u>55</u>	<u>53</u>	<u>52</u>		

The 1<sup>st</sup> received byte, Message Transmitter Identification, value 143, is the originator of the broadcast, meaning that the message was transmitted by an Acu-Trac® ultrasonic level transducer.

The 2<sup>nd</sup> byte, Service Code, value 254, is the proprietary service code designation used by SSI for all Acu-Trac® ultrasonic level transducer messages.

The 3<sup>rd</sup> byte, Message Receipt Identifier, value 177, denotes the intended recipient for the broadcast which is always a transceiver node number ≥ 128.

The 4<sup>th</sup> byte, Number of Remaining Characters, value 14, is the number of characters remaining in the message.

The 5<sup>th</sup> byte, Message Identifier, value 190, is the message identifier meaning that the message is a Measurement Broadcast.

The 6<sup>th</sup> byte, Number of Data Characters, value 12, is the number of data bytes in the message.

The 7<sup>th</sup> byte, Data, value 1, is the MSB of % of full scale capacity value.



# SSI Technologies - Application Note AT-AN14

## Acu-Trac® Smart 485 Messaging

The 8<sup>th</sup> byte, Data, value 64, is the LSB of the % of capacity value. Therefore the target location as a % of full scale capacity can now be calculated as follows:

$$\% \text{ of Capacity} = (\text{MSB} \times 256 + \text{LSB})/800$$

$$\% \text{ of capacity} = (1 \times 256 + 64)/800$$

$$\% \text{ of Capacity} = 40.0\%$$

The 9<sup>th</sup> byte, Data, value 1, is the MSB of the measurement. Based on the transducer's pre programmed unit scale.

The 10<sup>th</sup> byte, Data, value 224, is the LSB of the measurement. Based on the transducer's preprogrammed unit scale.

The 11<sup>th</sup> byte, Data, value 48, is an ASCII representation of the most significant digit of the serial

number which is 0.

The 12<sup>th</sup> byte, Data, value 48, is an ASCII representation of the next digit of the serial number which is 0.

The 13<sup>th</sup> byte, Data, value 48, is an ASCII representation of the next digit of the serial number which is 0.

The 14<sup>th</sup> byte, Data, value 51, is an ASCII representation of the next digit in the serial number which is 3.

The 15<sup>th</sup> byte, Data, value 51, is an ASCII representation of the next digit of the serial number which is 3.

The 16<sup>th</sup> byte, Data, value 50, is an ASCII

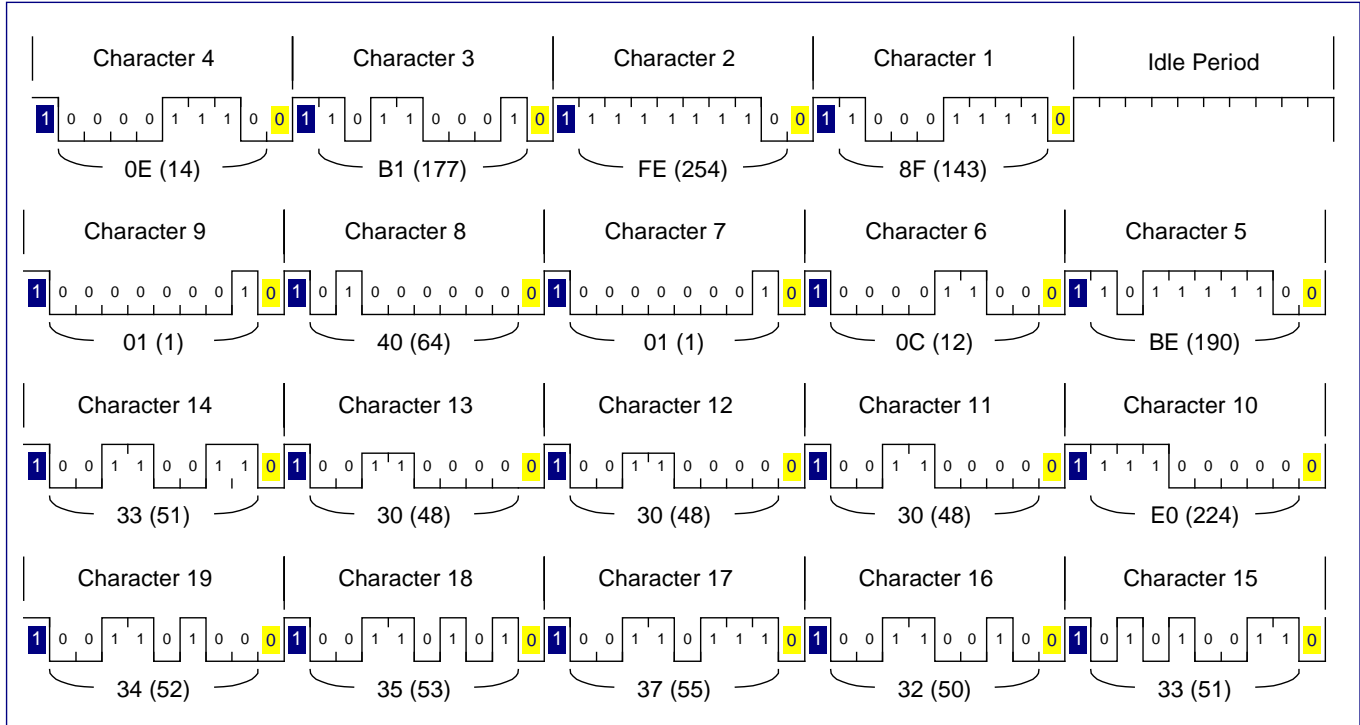

# SSI Technologies - Application Note AT-AN14

## Acu-Trac® Smart 485 Messaging

representation of the next digit of the serial number which is 2.

The 17<sup>th</sup> byte, Data, value 55, is an ASCII representation of the next digit in the serial number which is 7.

The 18<sup>th</sup> byte, Data value, 53, is an ASCII representation of the least significant digit in the serial number which is 5.

Based on received message bytes 11 through 18 we can now assemble the serial number as follows:

Byte11	Byte12	Byte13	Byte14	Byte15	Byte16	Byte17
0	0	0	3	3	2	7
Byte18						
5						

Serial number = 00033275

Knowing the serial number allows one to look up the transducer's operating mode and full scale range using a cross referenced table of values linked to the transducer's serial number.

For the purposes of this example we are using an Acu-Trac® Smart 485 ultrasonic level transducer with a full scale range of 30 inches operating in the rectilinear mode. To summarize:

Transducer serial: 00033275  
Operating Mode: Rectilinear  
Full Scale range: 150 gallons

Based on this data, we can now determine the actual volume in the tank using the measurement LSB, value 01, and MSB, value 224, contained within message bytes 9 and 10. The volume in the tank can be derived as follows:

$$\text{Volume} = (\text{MSB} \times 256 + \text{LSB})/8$$

$$\text{Volume} = (1 \times 256 + 224)/8 \text{ gallons}$$

$$\text{Volume} = 60.0 \text{ gallons}$$

The last byte in the message is the Checksum, value 52 or in hex 0x34. The checksum provides a convenient method for checking the validity of the message by using the two's complement sum of all of the data characters ignoring any carries generated along the way. For example:

Calculate the Sum of all the message bytes, Bytes1 through 19 = 1536

Convert 1536 to Hexadecimal = 0x600

Ignore the carries using only the least significant byte = 0x00 or 0 decimal

The result from the calculation was 0 meaning that the message was correctly received.

To summarize we can conclude from this message that the tank fitted with Ultrasonic level transducer serial number 00033275 has 60 gallons left.

### Transceiver Electrical Characteristics

The following electrical characteristics and conventions refer to the Serial Bus Node Diagram located on the next page.

Positive logic is used when referring to the state of transmitted inputs and receiver outputs. The 485 bus is considered to be at a logic high (1) state if the A line is at least 0.2 volts more positive than the B line. Conversely the 485 bus is considered to be at a logic low (0) state whenever the A line is 0.2 volts below that of the B line. The transceiver circuit utilizes a standard RS-485 transceiver connected to drive the differential



# SSI Technologies - Application Note AT-AN14

## Acu-Trac® Smart 485 Messaging

data bus into the logic low (0) state. The logic high state is controlled by the 4.7 k-ohm pull up resistor and the 4.7 k-ohm pull down resistors.

EMI suppression is facilitated by the 1nf capacitor in conjunction with the 47 ohm series resistor located on each line.

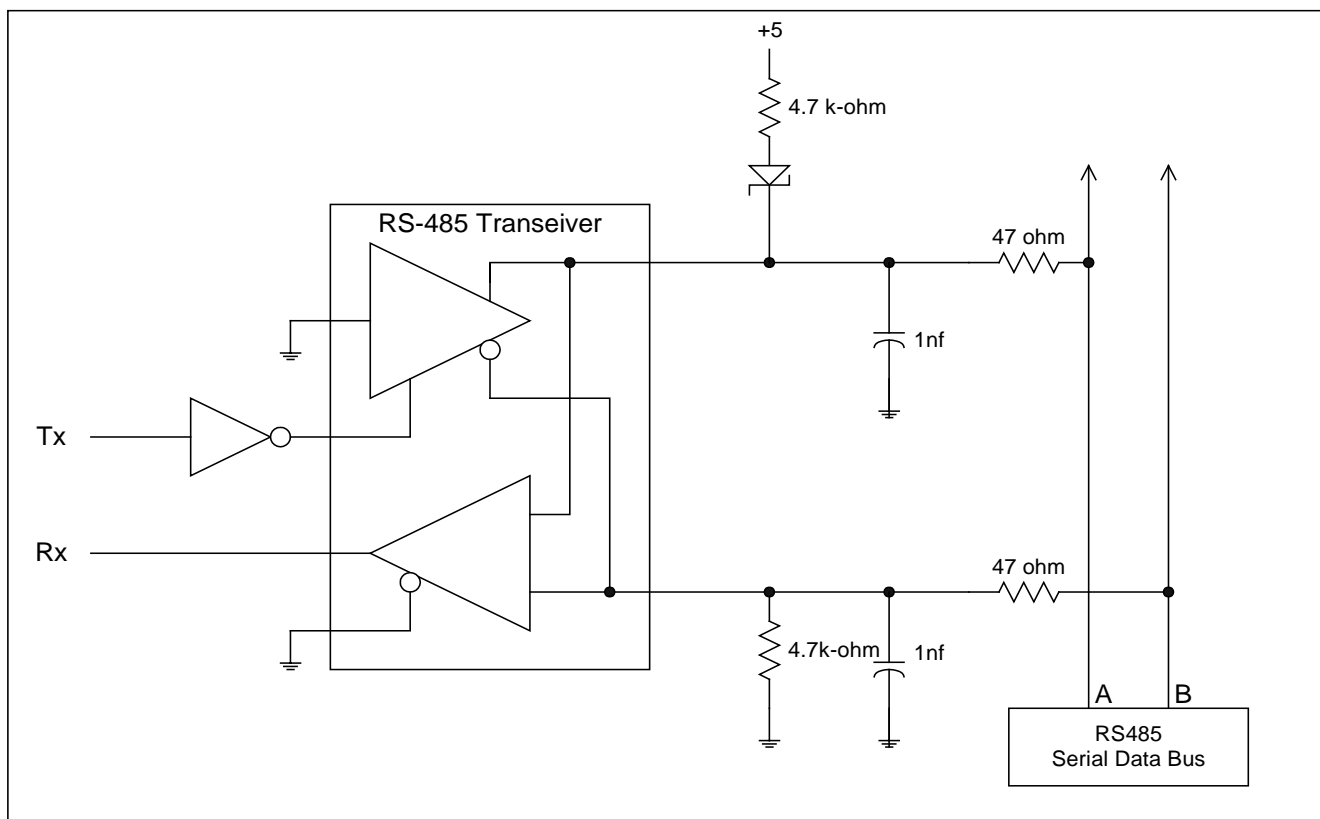

Serial Bus Node Diagram



# SSI Technologies - Application Note AT-AN14

## Acu-Trac® Smart 485 Messaging

### Timed Data Broadcast Message

The Acu-Trac® Smart 485 ultrasonic level transducer broadcasts over the SAE J1708 serial data link every 10 seconds a PID 96 level message.

<b>PID 96 Level</b>	Request	Automated PID 96 J1587 Standard Broadcast
	Response	143 96 D1 chk Where D1 Fuel level as a % of total capacity at 0.5%/bit

